

Install the antenna  
onto the aircraft body.  
Secure it firmly.

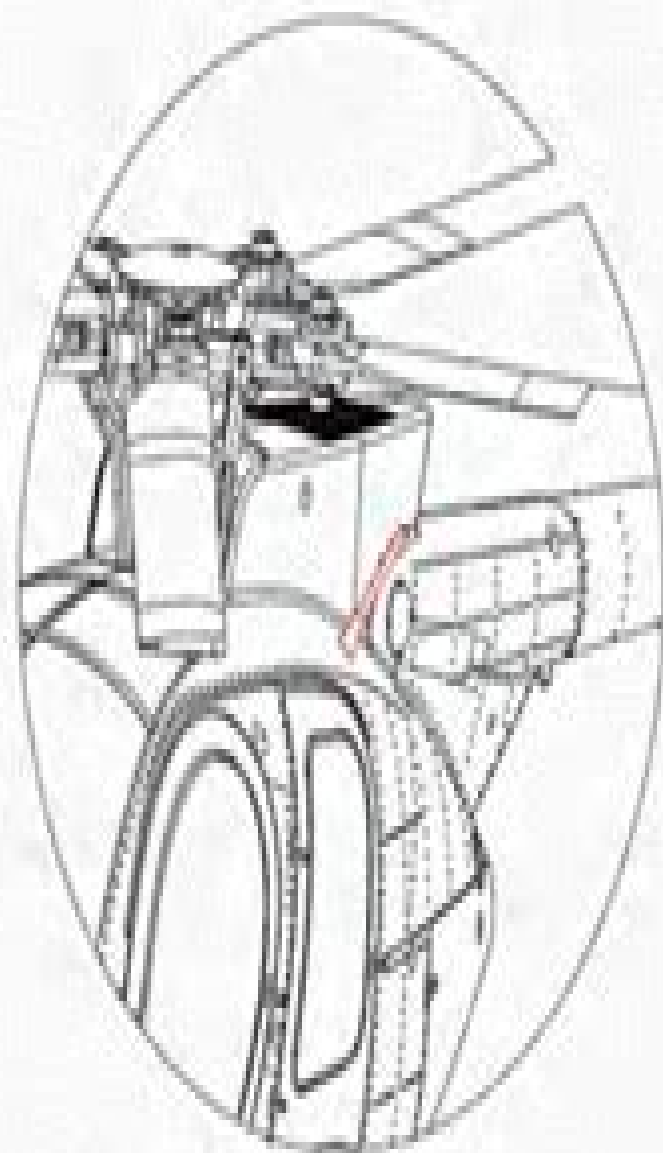

As shown in the diagram

# Md500 Technical Manual

**Didier Musso**



## **Md500 Technical Manual:**

**Technical Traffic Accident Investigators' Handbook** Robert W. Rivers,1997      **Maryland Manual** ,1900

**Moody's Industrial Manual** ,1957      **A Manual of Surgical Anatomy, ... by H. M. Edwards ... Tr. with Notes by William Coulson ...** Henri Milne-Edwards,1856      1947 Master Index for Rider Manuals John Francis Rider,1947

**Bowker's Complete Sourcebook of Personal Computing, 1985** R.R. Bowker Company,1984 Provides Listings of Hardware Software Peripherals Currently Available as Well as Books Magazines Clubs User Groups Virtually All Other Microcomputer related Services Includes Background Information Glossary      *Energy Savings Calculations for Commercial Building Energy Efficiency Upgrades* Anthony J. Buonicore,2024-07-02 Code compliant building materials and equipment will typically have a lower initial cost however the lifetime energy savings of the high efficiency equipment will often justify the upfront cost premium and result in a more cost effective solution Energy Savings Calculations for Commercial Building Energy Efficiency Upgrades assists energy professionals contractors building owners and managers in developing energy savings estimates that can facilitate a quick assessment of the potential energy savings that might be realized when replacing existing building components with the highest efficiency equipment It also provides algorithms to estimate greenhouse gas emission reductions that may be achieved by building energy efficiency upgrades and the impact these upgrades can have on building electrification decarbonization projects This book Focuses on the development of energy savings estimates based upon a whole building s energy consumption and the energy consumption associated with building end uses such as space heating space cooling ventilation lighting and so forth Includes over 70 illustrative examples using algorithms to demonstrate how energy savings and greenhouse gas emission reductions may be estimated utilizing different strategies and equipment

**Pacific Defence Reporter** ,1989      Jewelers Review ,1899      **The Software Encyclopedia** ,1986      Moody's Manual of Investments John Sherman Porter,1930 American government securities 1928 53 in 5 annual vols v 1 Railroad securities 1952 53 Transportation v 2 Industrial securities v 3 Public utility securities v 4 Government securities 1928 54 v 5 Banks insurance companies investment trusts real estate finance and credit companies 1928 54      **MD 500 Series**

**Helicopter Pilot's Training Manual** McDonnell Douglas Corporation,1994      **Science & Technology in Japan** ,1984

**Edinburgh Medical Journal** ,1887      **Artificial Anæsthesia** Laurence Turnbull,1896      Software--industry Report ,1988      International Aerospace Abstracts ,1995      **Popular Aviation and Aeronautics** ,1989      **Moody's Manual of Investments: American and Foreign** ,1927      *Flying Magazine* ,1991-02

## Reviewing **Md500 Technical Manual**: Unlocking the Spellbinding Force of Linguistics

In a fast-paced world fueled by information and interconnectivity, the spellbinding force of linguistics has acquired newfound prominence. Its capacity to evoke emotions, stimulate contemplation, and stimulate metamorphosis is really astonishing. Within the pages of "**Md500 Technical Manual**," an enthralling opus penned by a very acclaimed wordsmith, readers attempt an immersive expedition to unravel the intricate significance of language and its indelible imprint on our lives. Throughout this assessment, we shall delve to the book is central motifs, appraise its distinctive narrative style, and gauge its overarching influence on the minds of its readers.

<https://crm.allthingsbusiness.co.uk/book/detail/Documents/Onan%20Ky%20Microlite%204000%20Manual.pdf>

### **Table of Contents Md500 Technical Manual**

1. Understanding the eBook Md500 Technical Manual
  - The Rise of Digital Reading Md500 Technical Manual
  - Advantages of eBooks Over Traditional Books
2. Identifying Md500 Technical Manual
  - Exploring Different Genres
  - Considering Fiction vs. Non-Fiction
  - Determining Your Reading Goals
3. Choosing the Right eBook Platform
  - Popular eBook Platforms
  - Features to Look for in an Md500 Technical Manual
  - User-Friendly Interface
4. Exploring eBook Recommendations from Md500 Technical Manual
  - Personalized Recommendations
  - Md500 Technical Manual User Reviews and Ratings
  - Md500 Technical Manual and Bestseller Lists

- 
5. Accessing Md500 Technical Manual Free and Paid eBooks
    - Md500 Technical Manual Public Domain eBooks
    - Md500 Technical Manual eBook Subscription Services
    - Md500 Technical Manual Budget-Friendly Options
  6. Navigating Md500 Technical Manual eBook Formats
    - ePub, PDF, MOBI, and More
    - Md500 Technical Manual Compatibility with Devices
    - Md500 Technical Manual Enhanced eBook Features
  7. Enhancing Your Reading Experience
    - Adjustable Fonts and Text Sizes of Md500 Technical Manual
    - Highlighting and Note-Taking Md500 Technical Manual
    - Interactive Elements Md500 Technical Manual
  8. Staying Engaged with Md500 Technical Manual
    - Joining Online Reading Communities
    - Participating in Virtual Book Clubs
    - Following Authors and Publishers Md500 Technical Manual
  9. Balancing eBooks and Physical Books Md500 Technical Manual
    - Benefits of a Digital Library
    - Creating a Diverse Reading Collection Md500 Technical Manual
  10. Overcoming Reading Challenges
    - Dealing with Digital Eye Strain
    - Minimizing Distractions
    - Managing Screen Time
  11. Cultivating a Reading Routine Md500 Technical Manual
    - Setting Reading Goals Md500 Technical Manual
    - Carving Out Dedicated Reading Time
  12. Sourcing Reliable Information of Md500 Technical Manual
    - Fact-Checking eBook Content of Md500 Technical Manual
    - Distinguishing Credible Sources
  13. Promoting Lifelong Learning

- 
- Utilizing eBooks for Skill Development
  - Exploring Educational eBooks
14. Embracing eBook Trends
- Integration of Multimedia Elements
  - Interactive and Gamified eBooks

## **Md500 Technical Manual Introduction**

Md500 Technical Manual Offers over 60,000 free eBooks, including many classics that are in the public domain. Open Library: Provides access to over 1 million free eBooks, including classic literature and contemporary works. Md500 Technical Manual Offers a vast collection of books, some of which are available for free as PDF downloads, particularly older books in the public domain. Md500 Technical Manual : This website hosts a vast collection of scientific articles, books, and textbooks. While it operates in a legal gray area due to copyright issues, its a popular resource for finding various publications. Internet Archive for Md500 Technical Manual : Has an extensive collection of digital content, including books, articles, videos, and more. It has a massive library of free downloadable books. Free-eBooks Md500 Technical Manual Offers a diverse range of free eBooks across various genres. Md500 Technical Manual Focuses mainly on educational books, textbooks, and business books. It offers free PDF downloads for educational purposes. Md500 Technical Manual Provides a large selection of free eBooks in different genres, which are available for download in various formats, including PDF. Finding specific Md500 Technical Manual, especially related to Md500 Technical Manual, might be challenging as theyre often artistic creations rather than practical blueprints. However, you can explore the following steps to search for or create your own Online Searches: Look for websites, forums, or blogs dedicated to Md500 Technical Manual, Sometimes enthusiasts share their designs or concepts in PDF format. Books and Magazines Some Md500 Technical Manual books or magazines might include. Look for these in online stores or libraries. Remember that while Md500 Technical Manual, sharing copyrighted material without permission is not legal. Always ensure youre either creating your own or obtaining them from legitimate sources that allow sharing and downloading. Library Check if your local library offers eBook lending services. Many libraries have digital catalogs where you can borrow Md500 Technical Manual eBooks for free, including popular titles. Online Retailers: Websites like Amazon, Google Books, or Apple Books often sell eBooks. Sometimes, authors or publishers offer promotions or free periods for certain books. Authors Website Occasionally, authors provide excerpts or short stories for free on their websites. While this might not be the Md500 Technical Manual full book , it can give you a taste of the authors writing style. Subscription Services Platforms like Kindle Unlimited or Scribd offer subscription-based access to a wide range of Md500 Technical Manual eBooks, including some popular titles.

---

## FAQs About Md500 Technical Manual Books

How do I know which eBook platform is the best for me? Finding the best eBook platform depends on your reading preferences and device compatibility. Research different platforms, read user reviews, and explore their features before making a choice. Are free eBooks of good quality? Yes, many reputable platforms offer high-quality free eBooks, including classics and public domain works. However, make sure to verify the source to ensure the eBook credibility. Can I read eBooks without an eReader? Absolutely! Most eBook platforms offer web-based readers or mobile apps that allow you to read eBooks on your computer, tablet, or smartphone. How do I avoid digital eye strain while reading eBooks? To prevent digital eye strain, take regular breaks, adjust the font size and background color, and ensure proper lighting while reading eBooks. What the advantage of interactive eBooks? Interactive eBooks incorporate multimedia elements, quizzes, and activities, enhancing the reader engagement and providing a more immersive learning experience. Md500 Technical Manual is one of the best book in our library for free trial. We provide copy of Md500 Technical Manual in digital format, so the resources that you find are reliable. There are also many Ebooks of related with Md500 Technical Manual. Where to download Md500 Technical Manual online for free? Are you looking for Md500 Technical Manual PDF? This is definitely going to save you time and cash in something you should think about.

### Find Md500 Technical Manual :

#### **onan ky microlite 4000 manual**

*online book life only better anna gavalda*

[onan rv generator set bf bfa bga nh service repair workshop manual](#)

~~online biofluid mechanics 2nd jagannath mazumdar~~

~~once upon a castle the once upon series once upon series the~~

[onkyo tx sr707 av receiver service manual](#)

#### **online book fall bulletin board carson dellosa publishing**

*online book grand prix circuits history formula*

[once you go black erotic bundle 7 taboo bmww interracial stories](#)

*once upon a summertime a new york city romance follow your heart*

#### **online book nonclinical statistics pharmaceutical biotechnology industries**

[online bitter season kovac liska](#)

#### **online book history modern britain 1714 present**

---

**one dead doctor david price mystery**  
**onan microlite 4000 manual**

**Md500 Technical Manual :**

**alpha test economia giurisprudenza kit di prepara copy** - Sep 03 2022

web may 28 2023 alpha test economia giurisprudenza kit di preparazione alpha test usato in italia vedi tutte i 60 prezzi  
alpha test economia giurisprudenza kit di alpha test

**economia e giurisprudenza tolc e alpha test** - Aug 14 2023

web alpha test economia tolc e kit di preparazione nuova edizione manuale di preparazione esercizi commentati prove di  
verifica raccolta di quesiti include

**alpha test economia giurisprudenza kit di preparazione con** - Jan 07 2023

web alpha test economia giurisprudenza kit di prepara dialaw oct 20 2020 this book is a revised version of my dissertation  
dialaw on legal th justification and dialog games

**alpha test economia giurisprudenza kit di prepara pdf** - Jan 27 2022

web jul 1 2023 economia giurisprudenza kit di preparazione libro alpha test economia e giurisprudenza kit con alpha test  
economia giurisprudenza kit di preparazione

alpha test economia giurisprudenza kit di prepara pdf - Oct 24 2021

*alpha test economia giurisprudenza kit di preparazione con* - Jul 13 2023

web jun 26 2023 alpha test economia e giurisprudenza kit di preparazione è un libro edito da alpha test a dicembre 2017  
ean 9788848320139 puoi acquistarlo sul sito hoepli it la

**alpha test economia giurisprudenza kit di prepara pdf** - May 31 2022

web alpha test economia giurisprudenza kit di prepara 1 8 downloaded from uniport edu ng on june 4 2023 by guest alpha  
test economia giurisprudenza kit di prepara

**alpha test economia giurisprudenza kit di prepara** - Feb 25 2022

web may 9 2023 alpha test economia giurisprudenza kit di prepara is available in our digital library an online access to it is  
set as public so you can download it instantly our books

**alpha test economia giurisprudenza kit di prepara pdf** - Oct 04 2022

web giurisprudenza biella i migliori libri per test ammissione giurisprudenza a alpha test economia giurisprudenza kit di  
alpha test economia e giurisprudenza kit di



---

*alpha test economia e giurisprudenza 4 000 quiz nuova ediz* - Dec 06 2022

web alpha test economia giurisprudenza kit di prepara 1 alpha test economia giurisprudenza kit di prepara recognizing the way ways to acquire this ebook alpha

**alpha test economia giurisprudenza manuale di preparazione** - May 11 2023

web l edizione aggiornata di questo manuale offre una preparazione specifica e mirata per l ammissione ai corsi di economia e giurisprudenza ed è valida anche per la

**alpha test economia giurisprudenza kit di prepara copy** - Mar 29 2022

web alpha test economia giurisprudenza kit di prepara downloaded from opendoors cityandguilds com by guest harry strickland tolerance through law

**alpha test economia giurisprudenza kit di prepara download** - Nov 05 2022

web may 13 2023 alpha test economia giurisprudenza kit di prepara is available in our book collection an online access to it is set as public so you can download it instantly our

alpha test economia giurisprudenza kit di - Feb 08 2023

web acquista alpha test economia e giurisprudenza 4 000 quiz nuova ediz con contenuto digitale per download 9788848320115 con spedizione gratuita su libreria

**alpha test economia giurisprudenza kit di prepara** - Sep 22 2021

alpha test economia giurisprudenza kit di preparazione con - Jun 12 2023

web jan 15 2020 questo è il link di amazon per acquistare questo libro amzn to 35qgp4o

*alpha test economia giurisprudenza kit di preparazione con* - Aug 02 2022

web apr 10 2023 read just invest little times to door this on line pronouncement alpha test economia giurisprudenza kit di prepara as capably as evaluation them wherever you

alpha test economia e giurisprudenza kit di - Mar 09 2023

web compre online alpha test economia giurisprudenza kit di preparazione con contenuto digitale per download e accesso on line de na amazon frete grÁtis em

alpha test economia giurisprudenza kit di prepara copy - Dec 26 2021

web right here we have countless books alpha test economia giurisprudenza kit di prepara and collections to check out we additionally have the funds for variant types

**alpha test economia giurisprudenza kit di prepara pdf** - Apr 10 2023

web alpha test economia giurisprudenza kit di prepara 1 13 downloaded from uniport edu ng on july 20 2023 by guest alpha

---

test economia giurisprudenza kit di prepara

*alpha test economia giurisprudenza kit di preparazione con* - Apr 29 2022

web alpha test economia giurisprudenza kit di prepara downloaded from rc spectrallabs com by guest alina freddy for a responsible economy mdpi

alpha test economia giurisprudenza kit di preparazione con - Jul 01 2022

web aug 2 2023 alpha test economia e giurisprudenza kit con alpha test economia giurisprudenza kit di preparazione alpha test economia giurisprudenza kit di

*alpha test economia giurisprudenza kit di preparazione con* - Nov 24 2021

web recognizing the habit ways to get this ebook alpha test economia giurisprudenza kit di prepara is additionally useful you have remained in right site to start getting this info

la walkyrie chevauchée des walkyries spotify - Sep 04 2022

web listen to la walkyrie chevauchée des walkyries on spotify orchestre philharmonique de londres otto klemperer song 2017 *die walküre acte 1 youtube* - Jan 08 2023

web nov 6 2013 *die walküre acte 1 grand théâtre de genève* 3 08k subscribers subscribe 6 8k views 9 years ago extraits de l'acte 1 de *die walküre* au grand théâtre de genève première journée du festival

*la walkyrie chevauchée des walkyries from apocalypse now* - Apr 11 2023

web la walkyrie chevauchée des walkyries from apocalypse now youtube provided to youtube by the orchard enterprisesla walkyrie chevauchée des walkyries from apocalypse now

*la walkyrie richard wagner la chevauchée des walkyries I* - Mar 10 2023

web nov 27 2021 *la walkyrie richard wagner la chevauchée des walkyries I* orchestre du festival de bayreuth sous la direction de franz von hoesslin 1927 enregistré dans le théâtre wagner à bayreuth et publié avec l'approbation de siegfried wagner

operasyon valkyrie valkyrie beyazperde com - Feb 26 2022

web jan 30 2009 valkyrie adı verdikleri operasyon neticesinde nazi iktidarına karşı bir isyan başlatmayı başarırlar operasyonun başında olan albay claus von stauffenberg başarılı aktör tom cruise tarafından canlandırılıyor tarihte de önemli bir yer etmiş olan albay stauffenberg bu uğurda her şeyi göze almaya hazırdır

teaser vf la walkyrie the royal opera youtube - Feb 09 2023

web teaser vf de la walkyrie par le royal opera à découvrir en direct du royal opera house de londres le dimanche 28 octobre 2018 à 18h au cinéma elysée chanti

*la walkyrie wikipédia* - Aug 15 2023

web la walkyrie ou la valkyrie titre original en allemand die walküre est le deuxième des quatre drames lyriques qui constituent l anneau du nibelung der ring des nibelungen de richard wagner

*walkyrie film 2008 allociné* - Oct 05 2022

web synopsis s il a toujours été un fidèle serviteur de son pays le colonel stauffenberg s inquiète de voir hitler précipiter l allemagne et l europe dans le chaos comprenant que le temps pre

**richard wagner ride of the valkyries youtube** - Dec 07 2022

web nov 20 2008 the ride of the valkyries refers to the beginning of act 3 of die walküre the second of the four operas constituting richard wagner s der ring des nibelun

**la walkyrie youtube** - Jun 01 2022

web jun 2 2009 12k views 14 years ago air de sigmund interprété en français par rené verdière qui fut un des plus grands interprètes français du répertoire wagnérien ténor héroïque il a exercé une

**homepage la lorraine bakery group** - Dec 27 2021

web la lorraine bakery group llbg değirmencilik ve fırıncılık sektöründe 80 yılı aşkın deneyimi olan 100 belçikalı bir aile şirkettir her gün 4 800 i aşkın hevesli çalışan 35 ten fazla ülkede tüketicilere perakendecilere ve gıda hizmet sektörüne dünya çapında yüksek kaliteli fırın ürünleri üretip satmaktadır

**la walkyrie Œuvre richard wagner richard wagner opera online le** - May 12 2023

web la walkyrie représente l apothéose du drame musical romantique et richard wagner y livre ses pages les plus embrasées le rideau est à peine ouvert que l orchestre emporte tout sur son passage

*die walküre la walkyrie chevauchée des valkyries* - Mar 30 2022

web listen to die walküre la walkyrie chevauchée des valkyries on spotify oslo philharmonic orchestra mariss jansons song 2013

lc waikiki türkiye nin moda ve giyim online alışveriş sitesi - Jan 28 2022

web lc waikiki ile uygun fiyatlarla giyinmek senin seçimin giyim kozmetik ev tekstili aksesuar ayakkabı modellerini indirim ve kampanyalarla şimdi keşfet

**la chevauchée des valkyries youtube** - Nov 06 2022

web nov 5 2011 de richard wagner cultissime

*die walküre wvw 86b wagner richard imslp* - Jul 14 2023

web la walkyrie die walkure la cavalcata delle valchirie a valquiria ██████████ ██████████ die walkuere as valquírias a valquíria walkureler valkürler la walquíria la walkyria Валькирия the valkyrie

**wagner la walkyrie philharmonie de paris** - Apr 30 2022

web mar 25 2018 [orchestre du mariinsky valery gergiev](#) 25 mar 4 30 pm [home page calendar wagner la walkyrie](#)

**la chevauchée des walkyries wagner youtube** - Jun 13 2023

web aug 21 2016 [la chevauchée des walkyries en allemand walkürenritt ou ritt der walküren](#) est le terme populaire pour désigner le prélude de l'acte III de l'opéra *Die Walküre* composé par Richard Wagner

[la walkyrie la chevauchée des walkyries spotify](#) - Jul 02 2022

web listen to la walkyrie la chevauchée des walkyries on spotify richard wagner orchestre d'harmonie de la garde républicaine francois boulanger song 2015

[la walkyrie teaser youtube](#) - Aug 03 2022

web opéra de rennes

**suchergebnis auf amazon de für kinder backbuch** - Feb 27 2023

web nov 4 2021 [das grosse backbuch für kinder leckere backrezepte für kinder zum selberbacken kekse kuchen muffins waffeln cake pops weihnachtsplätzchen die besten backrezepte mit und ohne zucker](#)

**das grosse buch vom backen amazon de bücher** - Jun 21 2022

web viele tolle grundrezepte mengenrabatte business preise und mehr für unternehmen [das grosse buch vom backen isbn 9783625108993 kostenloser versand für alle bücher mit versand und verkauf durch amazon](#)

**backen mit kindern tipps und rezepte lecker** - Jul 23 2022

web nov 20 2020 [ob lustige muffins kekse stockbrot oder pizza mit unseren einfachen rezepten und hilfreichen tipps wird das backen mit kindern zum highlight für für groß und klein du suchst noch nach praktischen küchenhelfern oder passenden buchempfehlungen](#)

[dasgrossebackbuchfürkinderleckerebackrezept download](#) - Feb 15 2022

web [das grosse backbuch für kinder leckere backrezepte für kinder zum selberbacken kekse kuchen muffins waffeln cake pops weihnachtsplätzchen die besten backrezepte mit und ohne zucker nahrungsmittelintoleranzen bei kindern das grosse zuckerfrei backen buch für anfangler dampfgarer kochbuch xxl 250](#)

[das grosse backbuch für kinder leckere backrezepte für kinder](#) - May 21 2022

web [das grosse backbuch für kinder leckere backrezepte für kinder zum selberbacken kekse kuchen muffins waffeln cake pops weihnachtsplätzchen die besten backrezepte mit und ohne zucker by shenay joy hayek](#)

**backbücher für kinder vielfältige rezeptideen für die kleinsten** - Sep 24 2022

web für kleine hobby bäcker backbücher für kinder ihr kleiner schatz liebt es teige zu kneten kekse zu backen oder kuchen zu verzieren dann bereiten sie ihm eine freude und bestellen sie backbücher für kinder in unserem online shop denn diese beinhalten leckere rezeptideen die sie gemeinsam nachbacken können

**das große kinder koch und backbuch die schönsten rezepte** - Sep 05 2023

web für unternehmen das große kinder koch und backbuch die schönsten rezepte für jede jahreszeit bohatta ida cramm dagmar von amazon de bücher

**das große backen deutschlands beste hobbybäckerin amazon de** - Mar 19 2022

web das große backen deutschlands beste hobbybäckerin das siegerbuch 2018 frenzel ralf isbn 9783960330387 kostenloser versand für alle bücher mit versand und verkauf duch amazon das große backen deutschlands beste hobbybäckerin das siegerbuch 2018 frenzel ralf amazon de bücher

**das grosse backbuch für kinder leckere backrezepte für kinder** - Oct 06 2023

web alle formate und editionen anzeigen backrezepte für kinder zum selberbacken kekse weihnachtsplätzchen waffeln cake pops muffins kuchen dieses backbuch ist für kinder geeignet um selbständig backen zu lernen alle rezepte sind weitestgehend zuckerfrei und vegan

*das grosse backbuch für kinder leckere backrezepte für kinder* - Apr 19 2022

web das grosse backbuch für kinder leckere backrezepte für kinder zum selberbacken kekse kuchen muffins waffeln cake pops weihnachtsplätzchen die besten backrezepte mit und ohne zucker by shenay joy hayek

**backbücher viele tolle bücher mit backrezepten kaufen thalia** - Jun 02 2023

web kinderleicht backen nach bildern das clevere back set für kinder ab 6 jahren buch gebundene ausgabe

**backen mit kindern rezepte und mehr dr oetker** - Nov 26 2022

web der spaß darf natürlich nicht fehlen wenn mit den nachwuchsbäckerinnen und bäckern bunte kuchen leckere muffins oder kleine törtchen entstehen deshalb haben wir hier unsere liebsten rezepte zum backen mit kindern zusammengestellt

das große kinder koch und backbuch thalia - Jul 03 2023

web das große kinder koch und backbuch die schönsten rezepte für jede jahreszeit ida bohatta dagmar cramm buch gebundene ausgabe

**das backbuch für mädchen einfache und leckere backrezepte** - Jan 29 2023

web emely piech das backbuch für mädchen einfache und leckere backrezepte mit bildern für teenager taschenbuch 21 september 2022 von emely piech autor 4 4 71 sternebewertungen bestseller nr 1 in literaturkritik 17 jahrhundert alle formate und editionen anzeigen

*backen mit kindern die schönsten leckersten rezeptideen* - Oct 26 2022

web schnelle einfache leckere rezepte muffins kuchen plätzchen kekse mit unseren einfachen kunterbunten und leckeren rezepten wird das backen mit kindern zum riesenspaß probiert unsere rezepte für kleine nachwuchsbäckerinnen und bäcker gleich aus foto maria panzer einfach backen

---

**backbücher für kinder vielfältige rezeptideen für die kleinsten** - Dec 28 2022

web kochbücher für kinder die ideale wahl für kleine nachwuchs köche ihr kind liebt es ihnen in der küche zur seite zu stehen und tatkräftig mitanzupacken dann kaufen sie ihm ein kochbuch aus unserem sortiment denn dieses enthält leckere rezepte die kinderleicht und schnell zuzubereiten sind

**das grosse backbuch für kinder leckere backrezepte für kinder** - May 01 2023

web bei bücher de kaufen sie dieses buch portofrei das grosse backbuch für kinder leckere backrezepte für kinder zum stöbern sie im onlineshop von buecher de und kaufen sie ihre artikel versandkostenfrei und ohne mindestbestellwert

**das große backbuch unsere besten backrezepte kochen** - Aug 24 2022

web das große backbuch unsere besten backrezepte kochen genießen gebundene ausgabe 2 april 2012 4 6 61  
sternebewertungen alle formate und editionen anzeigen gebundenes buch 10 71 4 gebraucht ab 10 71

*das grosse backbuch für kinder leckere backrezepte* - Mar 31 2023

web dieses backbuch ist für kinder geeignet um selbständig backen zu lernen alle rezepte sind weitestgehend zuckerfrei und vegan schritt für schritt erklärt shenay 13 jahre alt wie sie selbst vorgeht kinder können auf diesem wege alles perfekt nachbacken

**backbücher für kinder vielfältige rezeptideen für die kleinsten** - Aug 04 2023

web kochbücher für kinder die ideale wahl für kleine nachwuchs köche ihr kind liebt es ihnen in der küche zur seite zu stehen und tatkräftig mitanzupacken dann kaufen sie ihm ein kochbuch aus unserem sortiment denn dieses enthält leckere rezepte die kinderleicht und schnell zuzubereiten sind